

# Comacchio GEO 305

## Hydraulic Crawler Drill



### Technical specifications :

**Weight :** 4.000 kg

#### **Undercarriage :**

Wheel Base : 1.500 mm

Max Width : 1.400 mm

Pad Width : 300 mm

Max. Climbing Ability : 36 %

Max. Speed : 1,5 km/h

#### **Power Pack :**

Diesel engine : Deutz TCD 2.9 L04

Emission Level : Step 3B/Tier 4

Engine power : 55,4 kW

Engine rpm : 2.300

Oil Tank : 160 l

Fuel Tank : 40 l

#### **Mast with gear reducer feed system :**

Feed Stroke : 1.600 – 3.600 mm

Total Length : 3.030 – 5.030 mm

Feed Force : 3.500 daN

Retract Force : 3.500 daN

#### **Rotary Head R 600 :**

Gears : 8

Max. Torque : 630 daNm

Max. Speed : 750 rpm

Head Passage : 92 mm

#### **Clamps :**

Clamping Range : 45 – 220 mm

Clamping Force : 130 KN

Breaking Torque : 1.000 daNm

#### **Included options :**

- Variable width undercarriage
- Rubber shoes for steel tracks
- Rod holder and combined breaker
- Single clamp
- Hydraulic breakout cylinder
- Towing Winch
- Mud pump
- Hydraulic drifter
- Pipe rack
- D.T.H. lubricator
- Washing kit
- CE Marking kit

#### **Rental fee :**

Comacchio Geo 305 : 550 €/day

#### **Possible options :**

- R600-EC20 : 200 €/day (Shank adapter H64RH X R32LH)
- Lutz : 100 €/day

06/02/2023

## Standard Set-Up

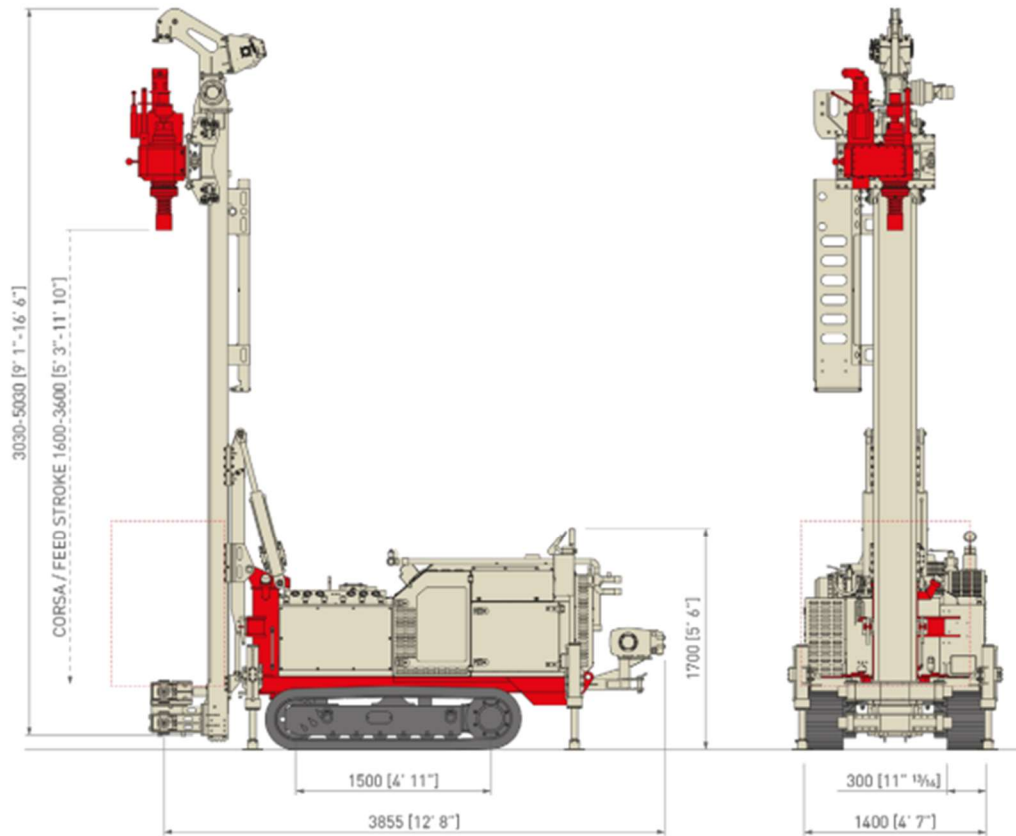

## Transport Dimensions

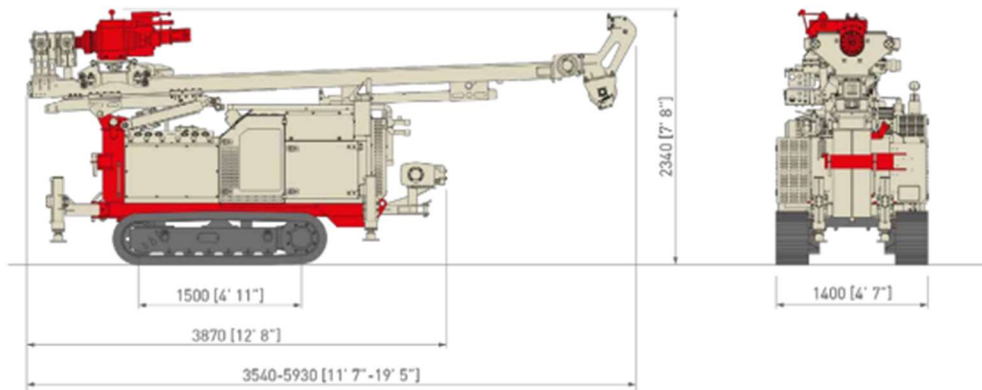

Chaussée de Bruxelles 206 – 7090 Braine-le-Comte – Belgium  
Tel : +32 (0)67 55 21 13 – [info@swalmec.be](mailto:info@swalmec.be) – [www.Swalmec.be](http://www.Swalmec.be)