

Comacchio CPH 3-2

Handling Unit

Specialty : The CPH is a patented Comacchio Casing & Pipe Handling Unit mountable on excavators.

Technical specifications :

Modèle/Version	CPH 3.2
Excavator Class	8 – 10 ton
Clamps	2
Clamping Range	85 – 305 mm
Max. Length – Single Tubes	2.000 - 6.000 mm
Max. Length – Dual Tubes	4.500 mm
Lifting Capacity	550 kg
Manipulator Weight	550 kg



Rental fee : 200 €/day

Adaptor : CW30 - 40

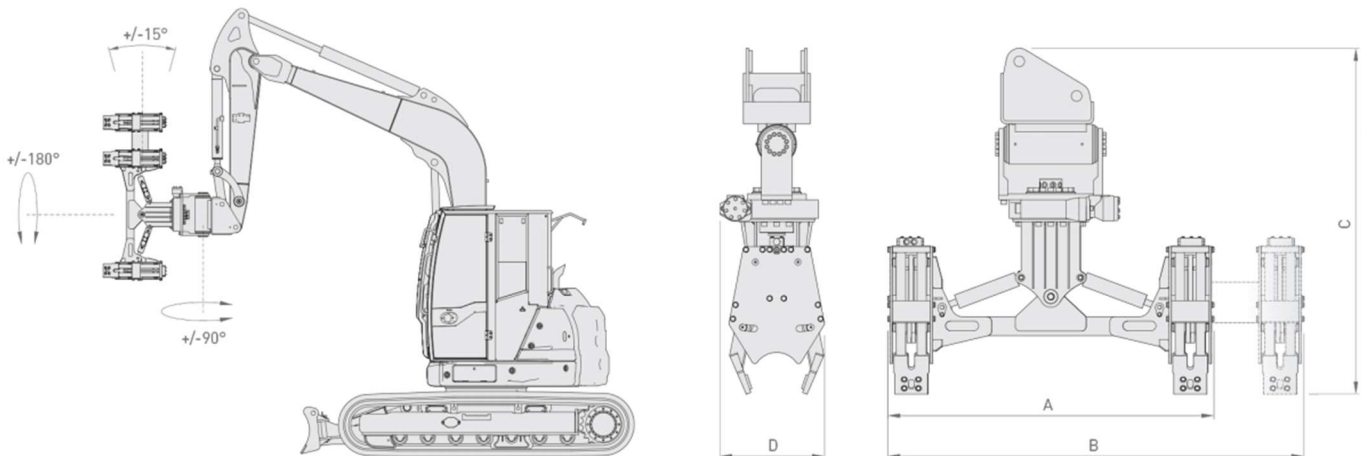

Model	CPH 3.2
A	1.980 mm
B	
C	1.650 mm
D	540 mm

06/02/2023



Chaussée de Bruxelles 206 – 7090 Braine-le-Comte – Belgium
Tel : +32 (0)67 55 21 13 – info@swalmec.be – [www. Swalmec.be](http://www.Swalmec.be)